

Operational amplifier – integrator and differentiator

1. Objectives

The aim of the exercise is to get to know the circuits with operational amplifiers suitable for linear signal transformation. The scope of the exercise includes the design and measurement of the basic parameters of the integrator and differentiator..

2. Components and instrumentation

The exercise examines the properties of an integrator and differentiator. These systems, built using operational amplifiers, are discussed in the following sections.

2.1. Integrator

The integrator performs the function of:

$$U_{OUT}(t) = \int U_{IN}(t)dt \quad (1)$$

Schematic diagram of a perfect integrator is shown in Fig. 2

In time domain the capacitor current can be expressed as:

$$I_C = C \frac{dU_{OUT}}{dt} \quad (2)$$

But the input current:

$$I_{IN} = \frac{U_{IN}(t)}{R} \quad (3)$$

Because of KCL:

$$I_{IN} + I_C = 0 \quad (4)$$

$$I_{IN} + I_C = \frac{U_{IN}(t)}{R} + C \frac{dU_{OUT}}{dt} = 0 \quad (5)$$

so:

$$U_{OUT}(t) = -\frac{1}{RC} \int U_{IN}(t)dt \quad (6)$$

Transfer function in frequency domain can be written as::

$$T_V(j\omega) = -\frac{1}{j\omega RCRC} \quad (7)$$

In the system of Fig. 2, there is no DC feedback, which in practice means saturation of the operational amplifier. Therefore, an additional resistor R1 was introduced (Fig.2). Such a system is called a lossy integrator.

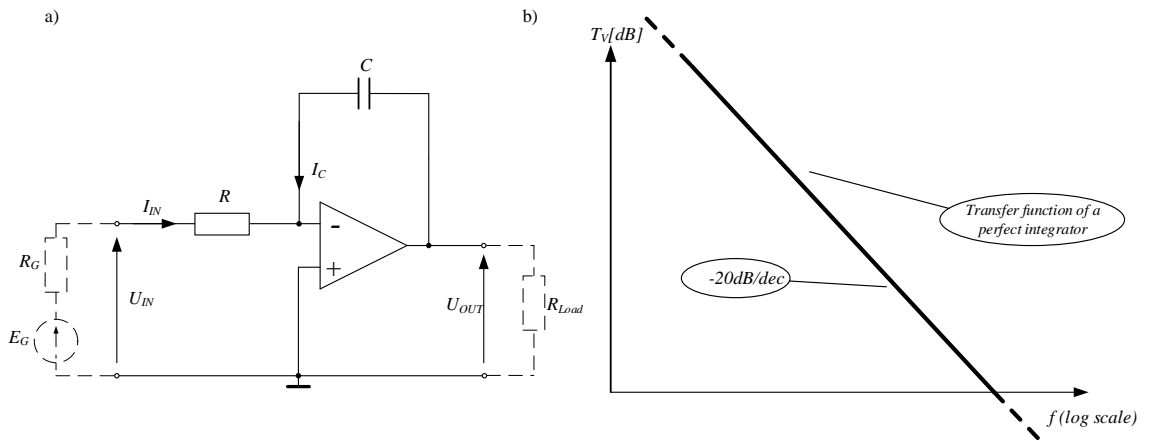

Fig. 1. Basic (perfect) integrator circuit a) schematic diagram, b) transfer function (absolute value) in dB vs. frequency in logarithmic scale.

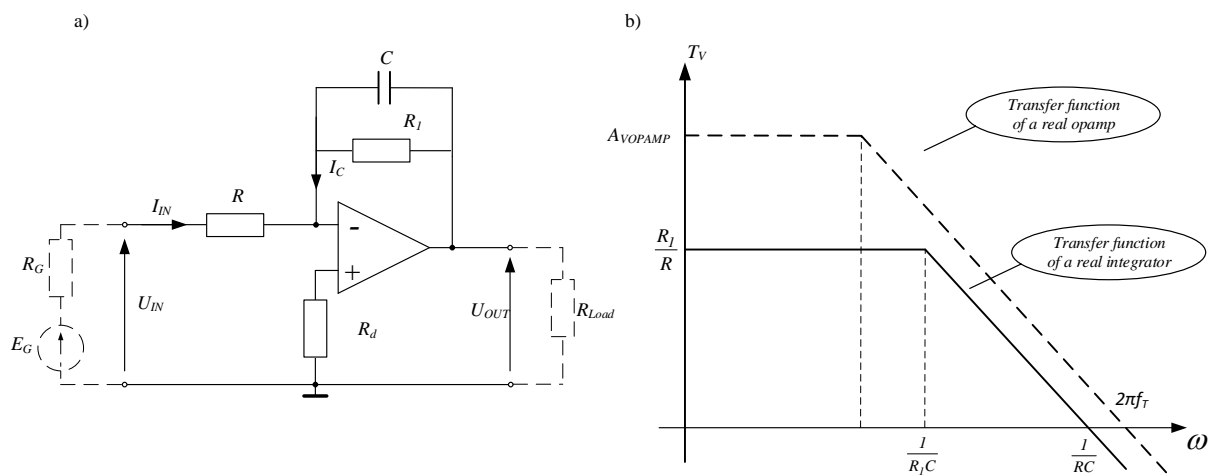

Fig. 2. Real integrator: a) schematic diagram, b) transfer function (abs) - fr gain bandwidth of a opamp.

The R_d resistor in the system in Fig. 3 is used to minimize the offset error,

$$R_d = \frac{(R_G + R)R_1}{R_G + R_1 + R} \quad (8)$$

where R_G the output resistivity of generator (usually 50Ω in the lab).

Transfer function of the real integrator shown in Fig.2 can be expressed in frequency domain as:

$$T_V(j\omega) = - \frac{R_1}{R} \cdot \frac{1}{1 + j\omega C R_1} \quad (9)$$

As it results from the course of the transfer function of this system (Fig.3), the correct integration takes place for ω (slope -20 dB / dec):

$$2\pi f_T \gg \omega > \frac{1}{R_1 C} \quad (10)$$

This, for sinusoidal waves, corresponds to period of sinewaves of period:

$$T < 2\pi C R_1 \quad (11)$$

2.1.1. Time domain relations

If we provide to the integrator input, a square wave with the peak-to-peak value $U_{INpp} = 2U_{INm}$ and the frequency $f = 1 / T$, on the output we get a triangular wave - Fig. 4. The phase change (minus sign) of the output signal results from formula (6).

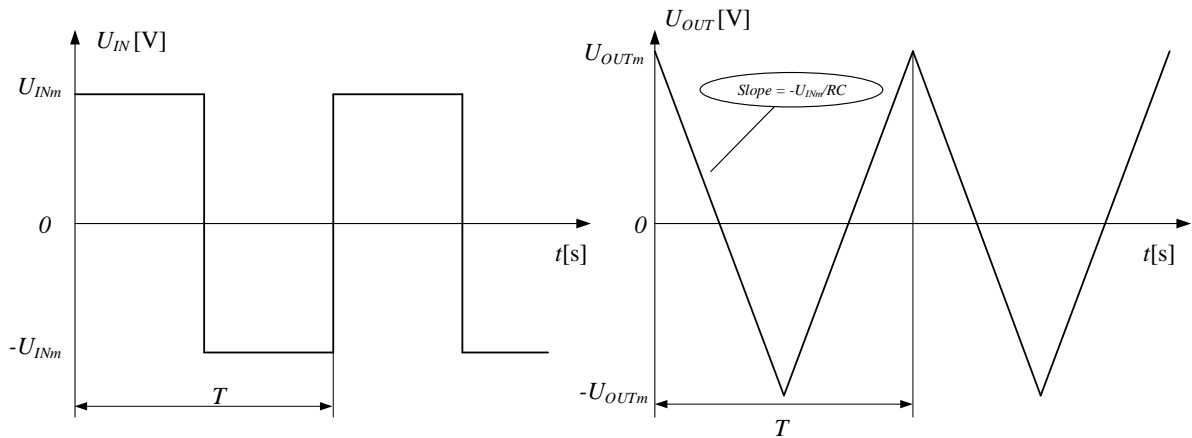

Fig. 3. A rectangular input waveform and the answer of the integrator.

For $0 \leq t \leq T/2$ falling slope of the triangle waveform can be written as:

$$U_{OUT}(t) = -\frac{U_{INm}}{RC} \frac{t}{2} + U_{OUTm} \quad (12)$$

For $t=T/2$, according to Fig.3 we get:

$$U_{OUTm} = \frac{U_{INm} T}{RC} \quad (13)$$

When designing a lossy integrator, first select the values of R and C, then the condition for correct integration (eq.11), resistor R_1

Example

task

Design a lossy integrator that will perform the integration function of a square wave signal with $U_{INm} = 1V$ and $T = 1ms$ per triangular signal with $U_{OUTm} = 1.5V$.

solution

Assuming $R = 10k\Omega$,

Capacitor C can be calculated (eq. 13):

$$C = \frac{U_{INm} T}{2U_{OUTm} R} = \frac{1V \cdot 1ms}{2 \cdot 1.5 \cdot 10k} = 33nF$$

From eq. (11) R_1 can be estimated as:

$$R_1 \gg \frac{T}{2\pi C} = 4.8k$$

So R_I can be taken $R_I = 10 \cdot 4.8 \text{k}\Omega \approx 51 \text{k}\Omega$

2.2. Differentiator

An perfect differentiator system performs the function:

$$U_{OUT}(t) = \frac{dU_{IN}(t)}{dt} \quad (14)$$

Basic schematic diagram of a differentiator is shown in Fig.4..

Analyzing this circuit in time domain we can put:

$I_R = \frac{U_{OUT}(t)}{R}$ and $I_{IN} = C \frac{dU_{IN}(t)}{dt}$. According to KCL:

$$I_{IN} + I_C = C \frac{dU_{IN}(t)}{dt} + \frac{U_{OUT}(t)}{R} = 0 \quad (15)$$

hence:

$$U_{OUT}(t) = -RC \frac{dU_{IN}(t)}{dt} \quad (16)$$

A perfect transfer function can be written as:

$$T_V(f) = -j\omega RC \quad (17)$$

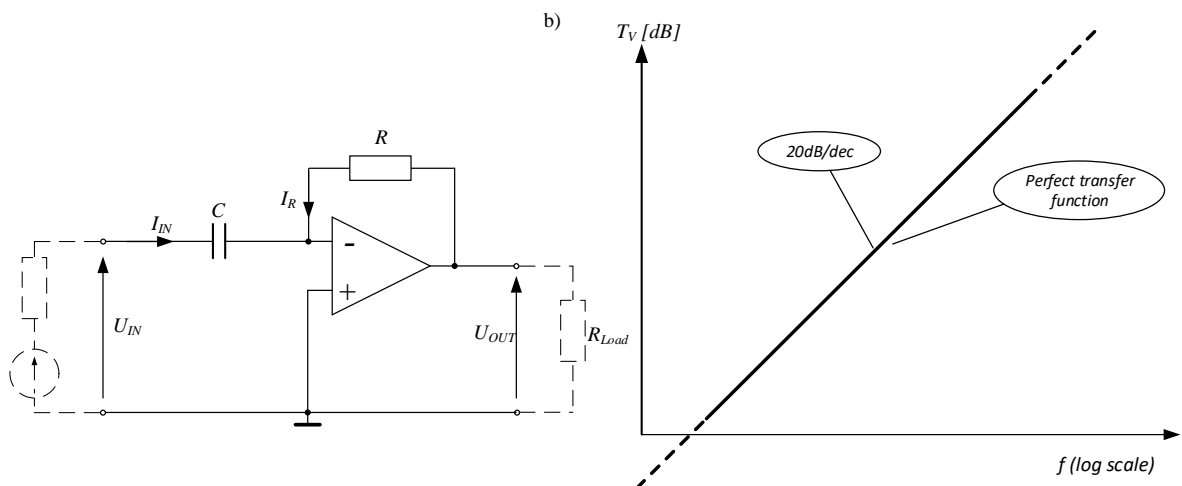

Fig. 4. Basic differentiator; a) schematic diagram, b) transfer function

The system performs the function of differentiation at pulsations at which the slope of the transfer function $T_V(\omega)$ is equal + 20 dB/dec.

The basic differentiator system has many disadvantages: tendency to instability, decrease in gain for higher frequencies associated with the frequency response of the opamp, very low input impedance at high frequencies, large input voltage noise. These defects can be reduced by introducing an additional R_1 resistor in the system. The diagram of the modified differentiator system is shown in Fig. 7

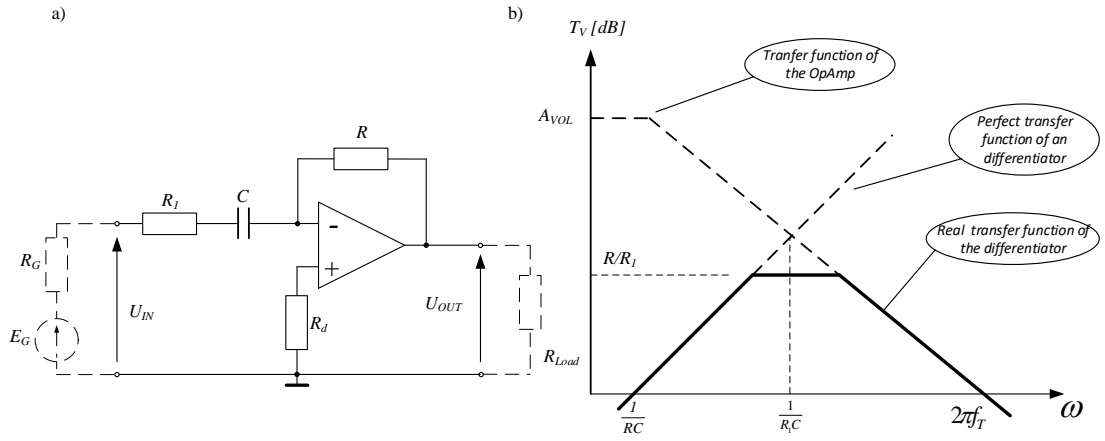

Fig. 5. Modified differentiator; a) schematic diagram, b) transfer function (abs).

Resistor R_d let minimize the offset of the opamp:.

$$R_d = R \quad (18)$$

Transfer function can be written as (perfect opamp):

$$T_V(f) = - \frac{j\omega RC}{1 + j\omega R_1 C} \quad (19)$$

As it results from the course of the Transfer function of this system (Fig. 7), the differentiation of sinusoidal signals takes place at frequencies f

$$f \ll \frac{1}{2\pi R_1 C} \ll f_T, \quad (20)$$

In practice R_1 , should be chose to fulfill the relation:

$$\frac{R}{R_1} \sqrt{\frac{1}{2\pi RC} \cdot f_T} < f_T \quad (21)$$

So:

$$R_1 > \sqrt{\frac{R}{2\pi C f_T}} \quad (21a)$$

where f_T gain bandwidth of opamp (for TL061 – 1MHz).

2.2.1. Time domain equations

Given the input of the differentiator from Fig.5, a triangular signal with a peak-to-peak value of $U_{INpp} = 2U_{INm}$ and frequency f , at the output of the system we get a rectangular signal with a peak-to-peak value of $U_{OUTpp} = 2U_{OUTm}$ - Fig.6.

For $0 \leq t \leq T/2$ Input signal can be described as:

$$U_{IN}(t) = \frac{2U_{INm}}{T/2} t - U_{INm} \quad (22)$$

So, according to eq.(16) and Fig.6 for $t=T/2$ we get:

$$U_{OUTm} = RC \frac{4U_{INm}}{T} \quad (23)$$

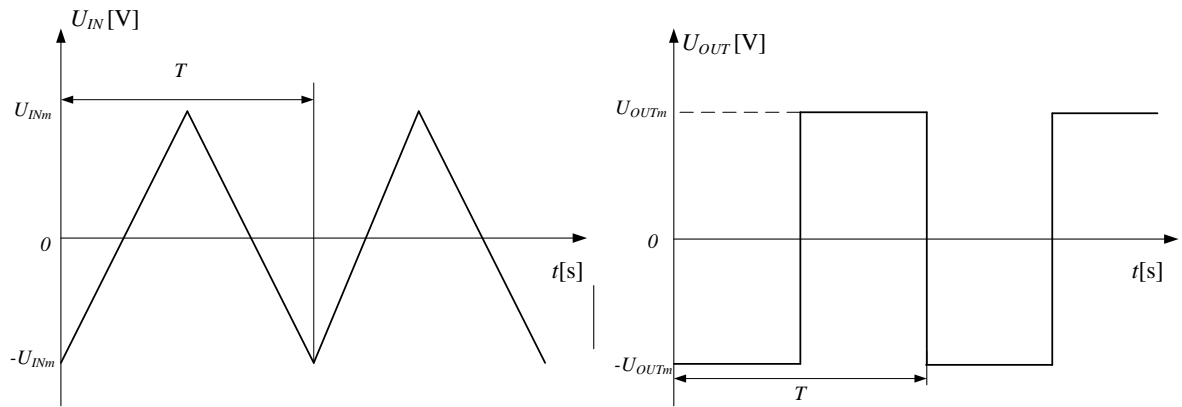

Fig. 6. Input and output signals of differentiator.

When designing the actual differentiator, we first select the R and C values, then the condition for the correct differentiation (21) resistor R_1

Example

task

Design a differentiator that will perform the function of differentiating a triangular signal with a voltage of $\pm U_{INm} = 0.5V$ and a period $T = 1ms$ per rectangular signal with voltages $\pm U_{OUTm} = 0.5V$.

solution

Assuming $R = 10k\Omega$.

We chose C (eq. 23):

$$C = \frac{U_{OUTm}}{4U_{INm}R} T \approx 25nF$$

and R_1 ,

$$R_1 > \sqrt{\frac{R}{2\pi f_T C}} \approx 250\Omega$$

So we can accept $R_1 = (1.5 \div 2) * 250 \approx 470\Omega$

3. Preparation

NOTICE: estimated preparation time can be as long as 3 to 6 hours.

3.1. Readings

[1] Lab materials and lectures of the course.

[2] U. Tietze, Ch. Schenk, Electronic circuits. Handbook for Designers and Applications, Springer, 2008, p. 730-739, .

[3] P. Horowitz, W. Hill, The Art of Electronics, Cambridge Univ. Press, London, 2015, p.223-261

3.2. Problems

1. Derive the formula for the output voltage of the integral circuit in the time domain.

2. Sketch the transfer function (amplitude and phase) of the perfect and real integrator (amplification in [dB], logarithmic frequency axis).
3. Sketch the transfer function (amplitude and phase) of the perfect and real differentiator (amplification in [dB], logarithmic frequency axis).
4. Derive formulas for the amplitude of the output of the integrator when excited by a rectangular signal with a given amplitude
5. Derive formulas for the amplitude of the output of the differentiator when excited by a triangle signal with a given amplitude
- 6.

3.3. Detailed preparation

Before classes, students receive a project task from the tutor like that described in examples above.

Solution of the task should include:

- 1) Design task, diagram and calculation of system elements. Values of passive elements should be selected from normalized series of values - resistors choose from a series of E24(5%), capacitors from the values available in the laboratory (360p, 1n, 1n5, 3n3, 4n7, 6n8, 10n, 15n, 22n, 100nF).
- 2) Computer simulations (e.g. in LTspice – for AC analysis, the frequency on logarithmic axis, gain in dB).
- 3) Sketch of the layout of the elements on the PCB.

4. Contest of the report

4.1. Assemble of the circuit

- 1) Bearing in mind that every passive element is made with a certain accuracy, before proceeding with assembly of the system, measure the actual values of used elements using the meter available on the stand.
- 2) Apply the actual values of the elements to the prepared circuit diagram.
- 3) Assemble the circuit board on the PCB.

4.2. Integrator

4.2.1. Time domain measurements (square – triangle waveforms)

- 4) Assemble the measuring system according to the diagram from Fig. 7, the tested system should be supplied with $\pm 12V$ voltage
- 5) Provide a rectangular signal from the generator with parameters compliant with the requirements of the design task. On the output voltage oscillogram, measure its peak-to-peak value $U_{OUTpp} = 2U_{OUTm}$ and compare with that calculated. If necessary, correct the values of the elements so as to obtain an output signal of parameters given in the task.
- 6) By changing the signal frequency from the generator, measure the $U_{OUTm} = f(1/f)$ relationship (the output signal should be triangular, use “amplitude” measurement rather than “peak-peak”),
- 7) Measure and plot the relation $U_{OUTm} = f(1/f) = f(T)$ (lin-lin axes) and compare with the theoretical one (eq.13).

NOTE: The $U_{OUTm} = f(1/f)$ graph cannot be called “the gain” of the system or its “transfer function”

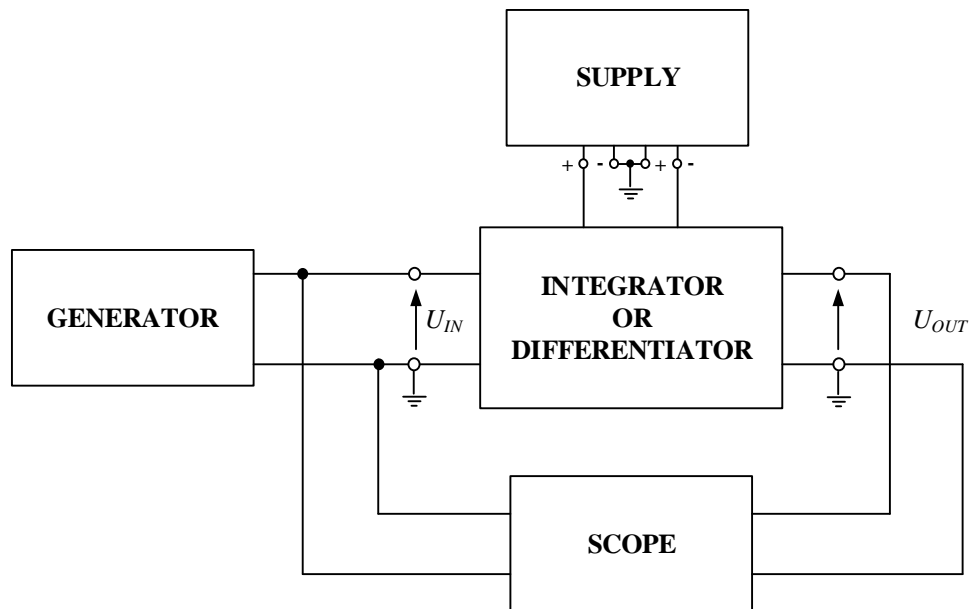

Fig. 7. Block diagram of measurement setup.

4.2.2. Frequency domain (sine waveform)

- 8) Using sine signals measure the transfer function (amplitude and phase). Use frequency range 10Hz to 5MHz (log axis). Amplitude of the signal should be chosen small enough to achieve undisturbed output signal and high enough to obtain real results. Measurements should be done by means of oscilloscope using RMS values (Cyc-RMS).
- 9) Put the results on the relevant graphs obtained in computer simulation

4.3. Differentiator

4.3.1. Time domain measurements (triangle – square waveforms)

- 4) Assemble the measuring system according to the diagram from Fig. 7, the tested system should be supplied with $\pm 12V$ voltage
- 5) Provide a triangle waveform from the generator with parameters compliant with the requirements of the design task. On the output voltage oscillogram, measure its peak-to-peak value $U_{OUTpp} = 2U_{OUTm}$ and compare with that calculated. If necessary, correct the values of the elements so as to obtain an output signal of parameters given in the task.
- 6) By changing the signal frequency from the generator, measure the $U_{OUTm} = f(f)$ relationship (the output signal should be squerwave, use “amplitude” measurement rather than “peak-peak”),
- 7) Measur and plot the relation $U_{OUTm} = f(f)$ (lin-lin axes) and compare with the theoretical one (eq.23).

NOTE: The $U_{OUTm} = f(f)$ graph can not be called “the gain” of the system or its” transfer function”

4.3.2. Frequency domain (sine waveform)

- 8) Using sine signals measure the transfer function (amplitude and phase). Use frequency range 10Hz to 5MHz (log axis). Amplitude of the signal should be chosen small enough to achieve undisturbed output signal and high enough to obtain real results. Measurements should be done by means of oscilloscope using RMS values (Cyc-RMS).
- 9) Put the results on the relevant graphs obtained in computer simulation

4.4. Report should include

- 1) Title page.
- 2) Calculation for task (p. 3.3),

- 3) Circuit diagram with marked values of elements calculated in the design task and free space, intended for entering real values measured at the laboratory stand
- 4) Result table measured relation $U_{OUTm} = f(f)$ (-for differentiator driven with square waveform) or $U_{OUTm} = f(T)$ (- for integrator driven with triangle waveform).
- 5) Graph of relations as in p.4) – lin-lin axes.
- 6) Result table for transfer function (amplitude and phase) measured with sine wave.
- 7) Graph of transfer function (amplitude[dB] and phase) measured, and calculated in computer program (e.g LTspice) in log–lin(dB) axes.
- 8) Conclusions. Discuss the differences between measured and calculated (or simulated) results – explain differences.

5. Appendix: Schematic diagram and PCB

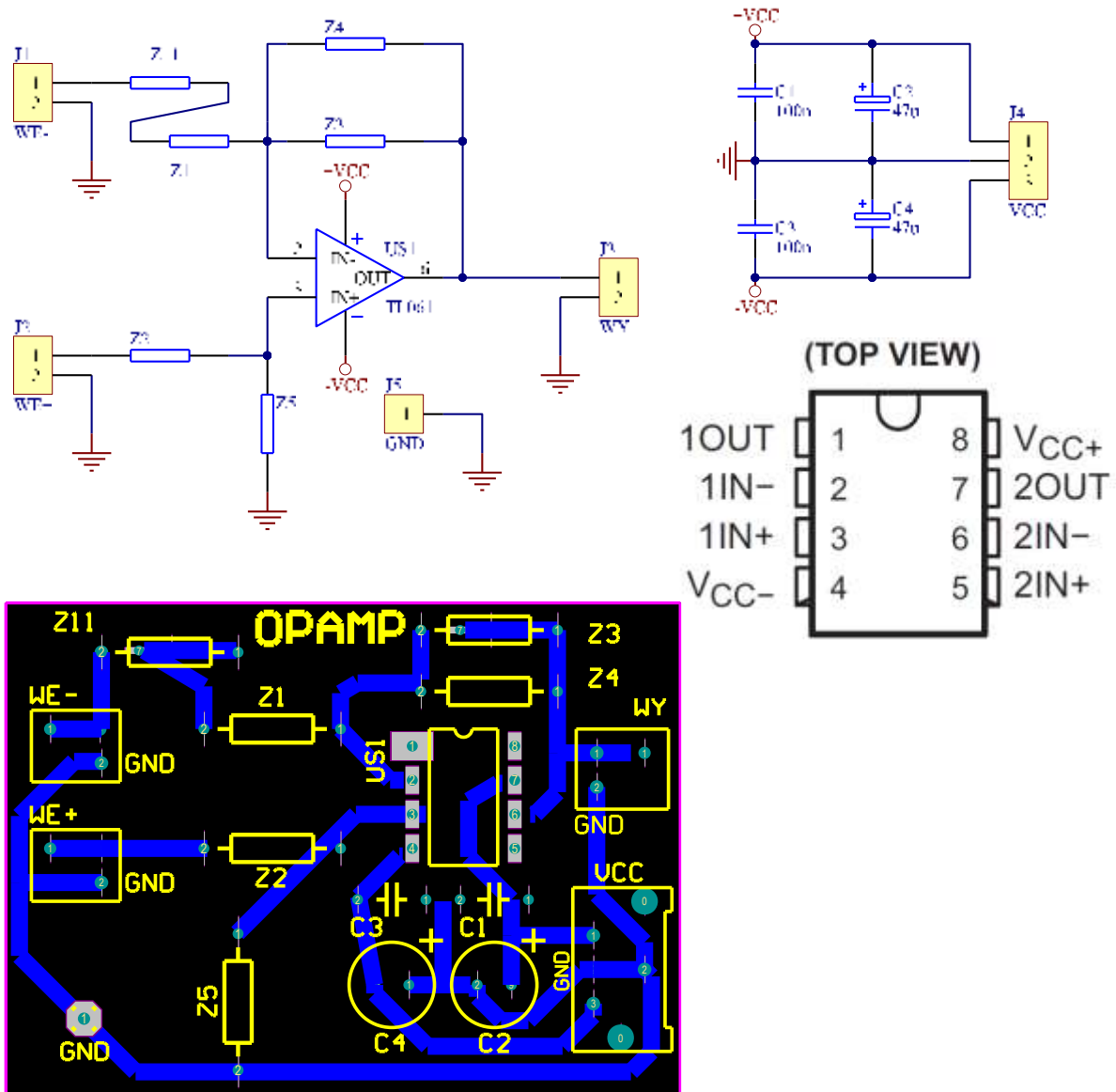

Fig. 8. View of the PCB, schematic diagram of the system, operational amplifier TL061 pins; C1-C4 capacitors are used for power decoupling and together with TL 061 are already soldered on the board.